

## PRODUCT PROFILE



144 x 144 x 50mm

## SPECIFICATIONS

Display	: Liquid crystal display with dual color backlight 3 line, 4 digits to show electrical parameters.
Wiring input	: 3 Ø 4 wire, 3 Ø 3 wire, 1 Ø 2 wire, 2 Ø 2 wire
Rated input voltage	: 11 to 300V AC (L-N) ; 50 to 520V AC (L-L)
Rated input current	: Nominal 5A AC (MIN-11mA, MAX-6A)
Burden	: 20 mOhms
Frequency range	: 45-65 Hz
CT primary	: 5A to 9999A (programmable for any value)
PT Primary	: 100V to 500kV (Programmable for any value)
PT Secondary	: 100V to 500V (Programmable for any value)
Display update time	: 1sec for all parameters
Display scrolling	: Auto / Manual / Default (Programmable)
Display scrolling time	: 5 Sec.
Power Consumption	: MAX 15VA
Trip Indication	: Backlight turns to orange □ symbol turns ON
Controlling Range	: Target PF : 0.800 lag to 0.800 lead Switching Program : Automatic
Relay Output	: 12 Relay(Additional 2 for FAN and Alarm)
Alarm mode	: Over Voltage, Under Voltage, Over Compensate, Under Compensate, CT Polarity error, No Voltage, THDI, Over Temperature.
Temperature	: 0 to 100°C
Fan Output	: ON / OFF / Temp controlled
LCD Indication	: 🔄 - Communication in Progress 🌀 - Fan Mode DI - Digital Input
Environmental Conditions: Outdoor use	Temperature : Operating : 0°C to 60°C Storage : -20°C to 60°C Humidity : 0% to 95% without moisture condensation
Mounting	: Panel Mounting
Weight	: 460gms

## ORDER CODE INFORMATION

PRODUCT	SUPPLY	CE	NO. OF STAGES
APFC148-312-90/550V	90 to 550V AC, 50/60Hz	—	12 / 14*

NOTE : \* When 14 relay option selected FAN & ALARM Relay will be used for control Switching

## SERIAL COMMUNICATION

Interface standard and protocol	RS485 AND MODBUS RTU
Communication address	1 to 255
Transmission Mode	Half duplex
Data types	Float and Integer
Transmission distance	500 Meter maximum
Transmission speed	300, 600, 1200, 2400, 4800, 9600, 19200 (in bps)
Parity	None, Odd, Even
Stop bits	1 or 2

## RESOLUTION

PT Ratio x CT Ratio	kWh	PT Ratio x CT Ratio	kWh
<15	0.01K	<15000	0.01M
<150	0.1K	<150000	0.1M
<1500	1K	≥150000	1M

NOTE : 1) For Voltage, Current, Power resolution is automatically adjusted.  
2) For power factor, resolution is 0.001 & for temperature resolution is 0.1

## ACCURACY

Measurement	Accuracy	Measurement	Accuracy
Voltage $V_{L-N}$	±0.5% of Full Scale	Active Power	1%
Voltage $V_{L-L}$	±0.5% of Full Scale	Apparent power	1%
Current	±0.5% of Full Scale	Reactive Power	1%
Frequency	±0.1% of Full Scale	Power factor	±0.01
For L-N > 20V, For L-L > 35V		Active energy	Class 1
Temperature	±3°C of Full Scale	Apparent energy	Class 1
		Reactive energy	Class 1

## SAFETY PRECAUTIONS

All safety related codification, symbols and instructions that appear in this operating manual or on the equipment must be strictly followed to ensure the safety of the operating personnel as well as the instrument.

If the equipment is not handled in a manner specified by the manufacturer, it might impair the protection provided by the equipment.

⚠ **CAUTION** : Read Complete instruction prior to installation and operation of the unit.

⚠ **WARNING** : Risk of electric shock.

## WIRING GUIDELINES

- To prevent the risk of electric shock, power supply to the equipment must be kept OFF while doing the wiring arrangement. Do not touch the terminals while power is being applied.
- Wiring shall be done strictly according to the terminal layout. Confirm that all connections are correct.
- Use pin type lugged terminals.
- To eliminate electromagnetic interference, use wires with adequate ratings and twists of the same in equal size shall be made.
- Cables used for connection to power source, must have a cross section of 1.5mm<sup>2</sup>. These wires shall have current carrying capacity of 5A.

## MAINTENANCE

- The equipment should be cleaned regularly to avoid blockage of ventilating Parts.
- Clean the equipment with a clean soft cloth. Do not use Isopropyl alcohol or any other cleaning agent.

## INSTALLATION GUIDELINES

## CAUTION

- This equipment, being built-in type, normally becomes a part of main control panel and in such case the terminals do not remain accessible to the user end after installation and internal wiring.
- Conductors must not come in contact with the internal circuitry of the equipment or else it may lead to a safety hazard that may in turn endanger life or cause electrical shock to the operator.
- Before disconnecting the secondary of the external current transformer from the equipment, make sure that the current transformer is short circuited to avoid risk of electrical shock and injury.
- The equipment shall not be installed in environmental condition other than those mentioned in this manual.
- Thermal dissipation of equipment is met through ventilation holes provided on chassis of equipment. Such ventilation holes shall not be obstructed else it can lead to a safety hazard.
- Connector screw must be tightened after installation.

## MECHANICAL INSTALLATION / DIMENSIONS

- Prepare panel cut out with proper dimensions as shown in the figure.
- Push the meter into the panel cutout. Secure the meter in its place by pushing the clamp on the rear side. The screw of the panel clamp must be in the farthest forward slot.
- For proper sealing tighten the screw evenly with required torque.

## CAUTION

The equipment in its installed state must not come in close proximity to any heating sources, caustic vapors, oils, steam or other unwanted process by product.

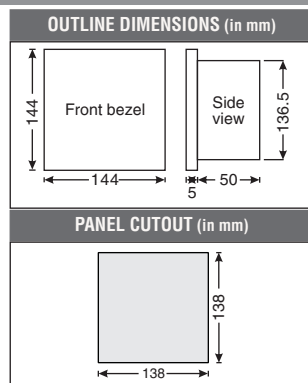

## EMC GUIDELINES

1. Use proper input power cables with shortest connections and twisted type.
2. Layout of connecting cables shall be away from any internal EMI source.

## SENSOR CLIP ASSEMBLY

Assemble sensor on the panel /Din rail clamp by using center screw provision and M4 nut. As shown in below diagram.

### 1. PANEL MOUNTING ASSEMBLY :

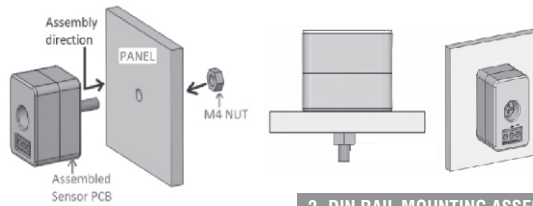

### 2. DIN RAIL MOUNTING ASSEMBLY :

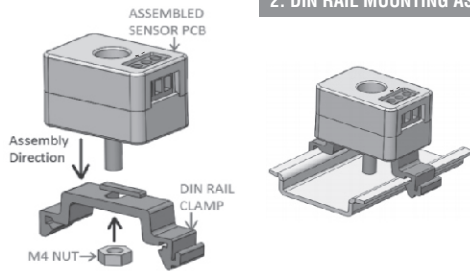

## FRONT PANEL DESCRIPTION

	KEY DESCRIPTION	
	Press  &	For 3 sec. to enter or exit from the configuration menu.
	Press	For increment
	Press	To move cursor right by one digit each time after last digit of display cursor shift at 1st digit of display.
	Press	To save the setting and move on to next page
	Press	To go back

## ONLINE PAGE DESCRIPTION

KEY PRESS	PARAMETER KEY	DESCRIPTION For 3P4W
—	—	Displays line to neutral voltage of 3 phases.
		Displays line to line voltage of 3 phases.
		Displays % THD of line to neutral voltage of 3 phases.
		Displays % THD of line to line voltage of 3 phases.
		Displays current of 3 phases.
		Displays % THD of current of 3 phases.
Press  key (1st time)	—	Displays line to neutral avg. voltage, current & frequency.
		Displays line to line avg. voltage, current & frequency.
		Displays power factor of 3 phases.
Press  key (2nd time)	—	Displays active power of 3 phases.
		Displays reactive power of 3 phases.
		Displays apparent power of 3 phases.
Press  key (3rd time)	—	Displays active energy.
		Displays apparent energy.
		Displays reactive energy.
		Displays temperature.

## SERIAL NUMBER DESCRIPTION

Press ESC () key for 10sec. to display 8 digit serial number at 2<sup>nd</sup> & 3<sup>rd</sup> line of display.

KEY PRESS	PARAMETER KEY	DESCRIPTION For 3P3W
—	—	Displays line to line voltage of 3 phases.
		Displays % THD of line to line voltage of 3 phases.
		Displays current of 3 phases.
		Displays % THD of current of 3 phases.
Press  key (1st time)	—	Displays line to line avg. voltage, current & frequency.
		Displays avg. power factor of 3 phases.
Press  key (2nd time)	—	Displays total active power.
		Displays total reactive power.
		Displays total apparent power.
Press  key (3rd time)	—	Displays active energy.
		Displays apparent energy.
		Displays reactive energy.
—		Displays temperature.

KEY PRESS	PARAMETER KEY	DESCRIPTION For 1P2W
—	—	Displays line to neutral voltage of 1st phase.
		Displays % THD of line to neutral voltage of 1st phase.
		Displays current of 1st phase.
Press  key (1st time)	—	Displays % THD of current of 1st phase.
	—	Displays power factor of 1st phase & frequency.
		Displays active power of 1st phase.
Press  key (2nd time)		Displays reactive power of 1st phase.
		Displays apparent power of 1st phase.
Press  key (3rd time)	—	Displays active energy of 1st phase.
		Displays apparent energy of 1st phase.
		Displays reactive energy of 1st phase.
—		Displays temperature.

KEY PRESS	PARAMETER KEY	DESCRIPTION For 2P2W
—	—	Displays line to line voltage.
		Displays % THD of line to line voltage.
		Displays current.
Press  key (1st time)		Displays % THD of current.
	—	Displays power factor and frequency.
	—	Displays total active power.
Press  key (2nd time)		Displays total reactive power.
		Displays total apparent power.
Press  key (3rd time)	—	Displays active energy.
		Displays apparent energy.
		Displays reactive energy.
—		Displays temperature.

## BACKLIGHT INDICATIONS

Backlight	DESCRIPTION
White	Capacitor Banks that are ON.
Orange	Fault condition occurred [Press ESC key to display trip parameter] Backlight turn to white again when user will press ESC key in fault condition. Trip parameters will be displayed for 3sec each.

**NOTE :** On occurrence of any new fault condition backlight turns Orange & on pressing ESC key all trip parameters will be displayed for 3sec. each.

## ONLINE PAGE MODE DESCRIPTION

### AUTO / MANUAL / DEFAULT MODE:

Press Enter () key for 3sec. to change online page mode.

## CT ERROR

If current connection is reversed, controller will show in which phase connection is reversed. If more than one phase reverse, it will display combination of both.  
1 - 1st phase, 2 - 2nd phase, 3 - 3rd phase

## TEST MODE

Press & for 3sec. to enter in Test Mode.

**NOTE :** Test mode checks all the relays present in product sequentially.

Turn ON DI manually when the DI CHECK page is displayed. DI status will be displayed & returns to online page.

## CT Primary settings at Power ON

1. At power ON, Controller will ask for CT Primary settings.
2. If user enters 'YES', then CT Primary page will appear where user need to enter CT Primary value & Press key to start Auto-Initialization.
3. If on CT SET page, user does not choose any option for 2 minutes, Controller will take CT Primary value as 5 and start Auto-Initialization.
4. If user sets CT primary value from configuration, user need to restart the controller.

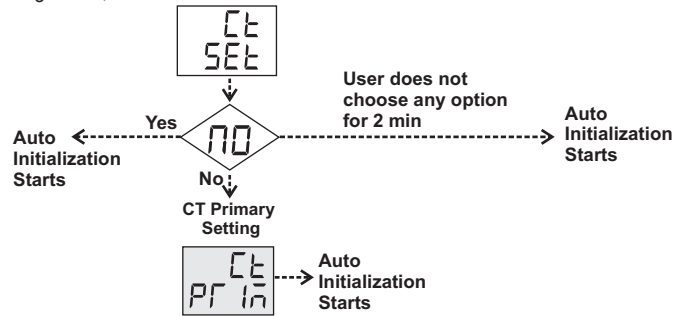

## CONFIGURATION MENU

There are 4 dedicated keys , , , .

Use these 4 keys to enter into configuration menu / change setting.

**NOTE :** The setting should be done by a professional after going through this operating manual.

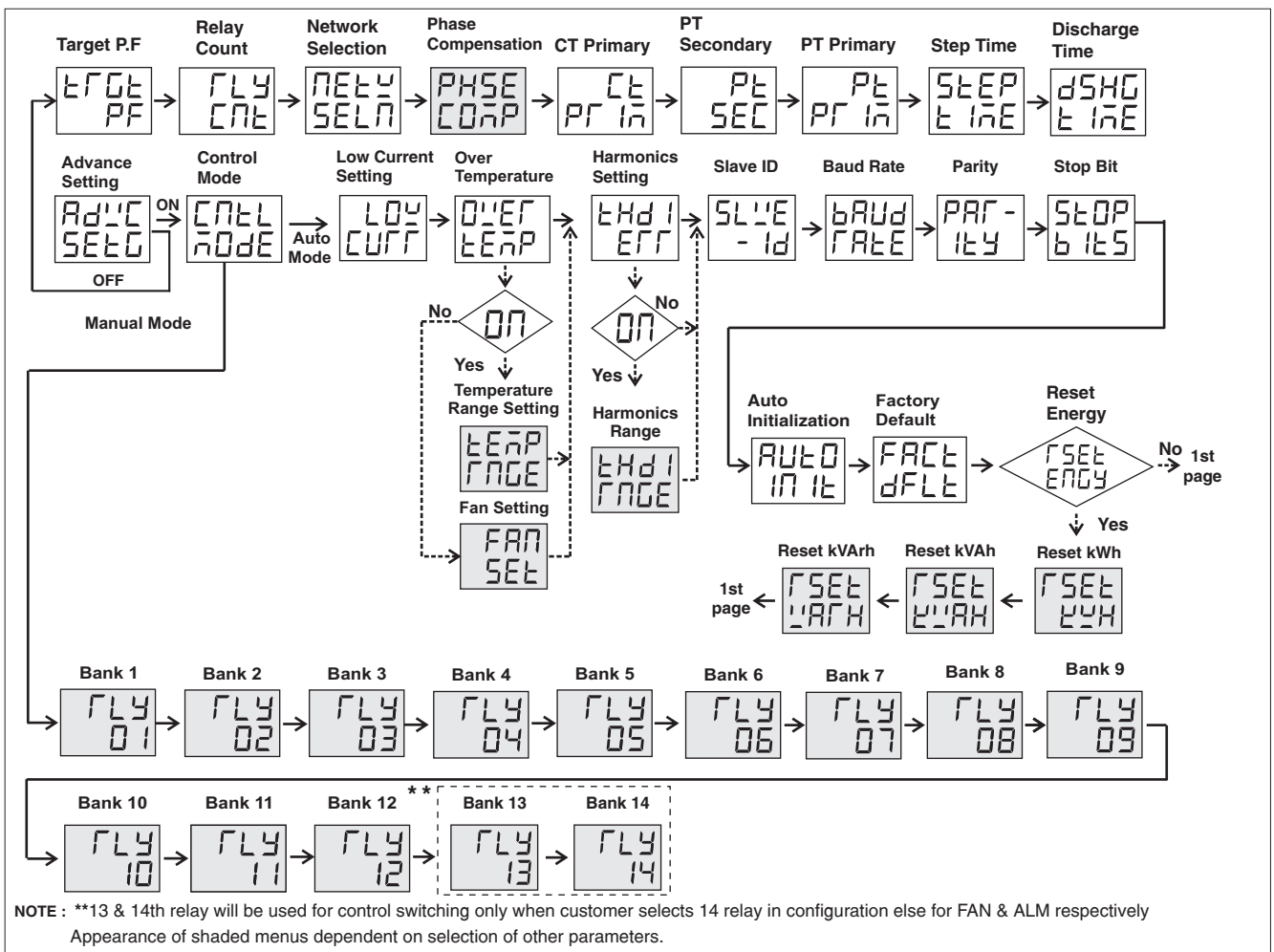

## CONFIGURATION TABLE

Parameter	Display	Range	Default Value	Condition
Target Power Factor	TRGT PF	0.800 to -0.800	1.000	
Relay Count	RLY CNT	1 – 14	12	
Network Selection	NETW SELN	3P4W / 3P3W / 1P2W / 2P2W	3P4W	
Phase Compensation Angle	PHSE COMP	0°, 90°, 120°, 210°, 240°, 330°	0°	Only Valid for 1P2W & 2P2W
CT Primary	CT PRIM	5A-9999A	5A	
PT Secondary	PT SEC	100V – 500V	350V	
PT Primary	PT PRIM	100V to 500KV	350V	
Step time	STEP TIME	5 s to 999 s	15 s	
Discharge Time (Reconnection time)	DSHG TIME	5 s to 999 s	40 s	
Advance Settings	ADV.S	ON/OFF	OFF	
Control Mode	CNTL MODE	AUTO/MANL	AUTO	
Relay 1	RLY1	ON / OFF	OFF	Prompted only if mode is set to manual.
Relay 2	RLY2	ON / OFF	OFF	
Relay 3	RLY3	ON / OFF	OFF	
Relay 4	RLY4	ON / OFF	OFF	
Relay 5	RLY5	ON / OFF	OFF	
Relay 6	RLY6	ON / OFF	OFF	
Relay 7	RLY7	ON / OFF	OFF	
Relay 8	RLY8	ON / OFF	OFF	
Relay 9	RLY9	ON / OFF	OFF	
Relay 10	RLY10	ON / OFF	OFF	
Relay 11	RLY11	ON / OFF	OFF	
Relay 12	RLY12	ON / OFF	OFF	
**Relay 13	RLY13	ON / OFF	OFF	
**Relay 14	RLY14	ON / OFF	OFF	

Parameter	Display	Range	Default Value	Condition
Over Temperature	OVER TEMP	ON/OFF	OFF	
Over Temperature Setting	TEMP RNGE	0-100 °C	65 °C	
FAN Setting	FAN SET	ON/OFF	OFF	Prompted only if Over temp is set to OFF
Total Harmonic Distortion	THDI ERR	ON/OFF	OFF	
THD I Range	THDI RANG	20-100%	50%	Prompted only if THDI ERR is set to ON
Slave ID	SLVE ID	001 – 255	1	
Baud Rate	BAUD RATE	300/600/1200/2400/4800/9600/19K2	9600	
Parity	PAR-ITY	NONE / ODD / EVEN	NONE	
Stop Bits	STOP BITS	1 or 2	1	
Auto Initialization	A.INT	NO / YES	YES	
Factory Default	FACT DFLT	YES / NO	NO	
Reset Energy	RSET ENGY	YES / NO	NO	
Reset kWh	RSET kWh	YES / NO	NO	Prompted only if Reset Energy is set to YES
Reset kVAh	RSET kVAh	YES / NO	NO	
Reset kVArh	RSET VArh	YES / NO	NO	

**NOTE :** \*\*13 & 14th relay will be used for control switching only when customer selects 14 relay in configuration else for FAN & ALM respectively

## TRIP TIME

Parameter	Display	Activate	Deactivate	Action to be taken by APFC
No Voltage	NO VOLT	1 min	1 min	Disconnect All Steps
Over Voltage	OVER VOLT			
Under Voltage	UNDR VOLT			
Over Compensation	OVER COMP			
Under Compensation	UNDR COMP			
CT Polarity Error	CT ERR			
Over Temperature	OVER TEMP			
THDI Error	THDI ERR	5 min	2.5 min	Disconnect All Steps

## FAN SETTINGS

SETTING	DESCRIPTION
None	Fan output permanently off.
Fixed On	Fan output permanently on.
Temperature ON/OFF (Setting range = 0°C - 100°C)	Fan output will turn on when the temperature exceed user set value.

## NOTE

- A.INT will be update to 'NO' automatically in configuration after auto initialization completion.
- Reauto - Initialization will be done by only changing A.INT - Yes in configuration manually.
- If DI is high controller work in manual mode & if Low return to 'Auto' mode.
- Recommended that number of relays not to be changed during normal operation.If done so, restart the controller.
- Recommended that CT ratio not to be changed during normal operation. If done so, Reauto-Initialize the controller.

## FIXED PARAMETER SETTINGS

Parameter	Default Value	Status
Over Voltage	15% of 240V for LN 15% of 415V for LL	ON
Under Voltage	15% of 240V for LN 15% of 415V for LL	ON
Over Compensation	-	ON
Under Compensation	-	ON
CT secondary	5A	-
C/K Setting	60%	-
Nominal voltage	VLL : 415V VLN : 240V	-
No Voltage	VLN < 50V VLL < 86V	ON

## USER GUIDE

- a) **Manual switching (MANL) :** 1) When this switching program is selected, the capacitor steps are controlled manually by the user.
- 2) **DI :** When user selects Manual switching through Auto / Manual switch on the panel, then all the relays that are 'ON' through APFC are turned 'OFF' and then user can manually turn every capacitor bank through push button available on panel for respective banks. In this case APFC has no more control and it switches off all bank that it was earlier controlling.
- b) **Automatic switching (AUTO) :** This automatic switching program uses intelligent switching sequence. The step switching sequence is not fixed and the program automatically selects the most appropriate steps to switch in or out in order to achieve shortest reaction time with minimum number of steps.

**MODBUS REGISTER ADDRESSES LIST**

**Readable parameters: [For Measuring: Length (Register) : 2; Data structure : Float, For Error: Length (Register) : 1; Data structure: Integer]**

Address	Hex Address	Parameter	Address	Hex Address	Parameter
30000	0x00	Voltage V1N	30046	0x2E	Total kVAr
30002	0x02	Voltage V2N	30048	0x30	PF1
30004	0x04	Voltage V3N	30050	0x32	PF2
30006	0x06	Average Voltage LN	30052	0x34	PF3
30008	0x08	Voltage V12	30054	0x36	Average PF
30010	0x0A	Voltage V23	30056	0x38	Frequency
30012	0x0C	Voltage V31	30058	0x3A	kWh
30014	0x0E	Average Voltage LL	30060	0x3C	kVAh
30016	0x10	Current I1	30062	0x3E	kVArh
30018	0x12	Current I2	30064	0x40	Temperature
30020	0x14	Current I3	30066	0x42	No Voltage Error
30022	0x16	Average Current	30067	0x43	Under Voltage Error
30024	0x18	kW1	30068	0x44	Over Voltage Error
30026	0x1A	kW2	30069	0x45	THD I Error
30028	0x1C	kW3	30070	0x46	Temperature Error
30030	0x1E	kVA1	30071	0x47	Over compensate Error
30032	0x20	kVA2	30072	0x48	Under compensate Error
30034	0x22	kVA3	30073	0x49	CT Error
30036	0x24	kVAr1	Note : For Error 0 :No Error ; 1 :Error Present		
30038	0x26	kVAr2	30074	0x4A-0x57	Relay1-Relay12/14* Status
30040	0x28	kVAr3	30088	0x58	Digital Input Status
30042	0x2A	Total kW	Note: For Status 0:OFF;1:ON		
30044	0x2C	Total kVA			

Address	Hex Address	Parameter
30090-30116	0x5A-0x74	Bank1 - Bank 12/14* Value
Total Harmonic Distortion(THD)		
30124	0x7C	THD of Voltage V1N
30126	0x7E	THD of Voltage V2N
30128	0x80	THD of Voltage V3N
30130	0x82	THD of Voltage V12
30132	0x84	THD of Voltage V23
30134	0x86	THD of Voltage V31
30136	0x88	THD of Current I1
30138	0x8A	THD of Current I2
30140	0x8C	THD of Current I3
30684	0x2AC	Serial number in HEX
<b>Formula to find address of individual Harmonic</b>		
Constant Parameter	Meaning	
0	Voltage V1N	
1	Voltage V2N	
2	Voltage V3N	
3	Voltage V12	
4	Voltage V23	
5	Voltage V31	
6	Current I1	
7	Current I2	
8	Current I3	

{142 + [(Harmonic no-2) x 2] + 60 x Constant Parameter }  
 For Example,  
 To find the 14<sup>th</sup> Harmonic address of Voltage V31 following formula can be used:  
 Formula with the parameter :  
 {142 + [(Harmonic no-2) x 2] + 60 x C P}  
 Eg. {142 + [(14-2) x 2] + 60 x 5} = 466  
 So, Check the 14<sup>th</sup> Harmonic of Voltage V31 at 466 address.

Read Coil Status		
Address	Hex Address	Parameter
00000-00013	0x00-0x0D	Relay1 - Relay 12/14*

Force Single Coil:		
Address	Hex Address	Parameter
00000-00013	0x00-0x0D	Relay1 - Relay 12/14*

\*13 & 14th relay will be used for control switching only when customer selects 14 relay in config. else for FAN & ALM respectively.

**Readable / writable parameters :**

Address	Hex Address	Parameter	Range		Length (Register)	Data Structure
			Min value	Max value		
40000	0x00	Target PF	800	-800	1	Integer
40001	0x01	Relay Count	1	12/14*	1	Integer
			Value	Meaning		
40002	0x02	N/W selection	0	3P4W	1	Integer
			1	3P3W		
			2	1P2W		
			3	2P2W		
40003	0x03	Phase Compensation (°)	0	0	1	Integer
			1	90		
			2	120		
			3	210		
			4	240		
			5	330		
			Min value	Max value		
40004	0x04	CT primary (A)	5	9999	1	Integer
40005	0x05	PT Secondary (V)	100	500	1	Integer
40006	0x06	PT Primary (V)	100	500000	2	Integer
40008	0x08	Step Time(sec.)	5	999	1	Integer
40009	0x09	Discharge Time (sec.)	5	999	1	Integer
40010	0x0A	Advanced Setting	0:OFF ; 1:ON		1	Integer
40011	0x0B	Control Mode	0-Manual ; 1- Auto		1	Integer
40012-40025	0x0C-0x19	Relay1 - Relay14	0:OFF ; 1:ON		1	Integer
40026	0x1A	Low Current Setting(%)	0	50	1	Integer
40027	0x1B	Over Temperature	0:OFF ; 1:ON		1	Integer
40028	0x1C	Set Over Temperature(°C)	0	100	1	Integer

Address	Hex Address	Parameter	Range		Length (Register)	Data Structure
			Min value	Max value		
40029	0x1D	Fan Settings	0:OFF ; 1:ON		1	Integer
40030	0x1E	THDI	0:OFF ; 1:ON		1	Integer
40031	0x1F	THDI Range	20	100	1	Integer
40032	0x20	Slave id	1	255	1	Integer
			Value	Meaning		
40033	0x21	Baud rate (bps)	0	300	1	Integer
			1	600		
			2	1200		
			3	2400		
			4	4800		
			5	9600		
			6	19200		
40034	0x22	Parity	0	None	1	Integer
			1	Odd		
			2	Even		
40035	0x23	Stop bit	0	1	1	Integer
			1	2		
40036	0x24	Auto Initialization	0: NO ; 1: YES		1	Integer
40037	0x25	Factory Default	1	Set to factory setting range	1	Integer
40038	0x26	Reset kWh	1	Reset Total Active Energy	1	Integer
40039	0x27	Reset kVAh	1	Reset Total Apparent Energy	1	Integer
40040	0x28	Reset kVArh	1	Reset Total Reactive Energy	1	Integer

**WIRING DIAGRAM**

**3 PHASE - 4 WIRE**

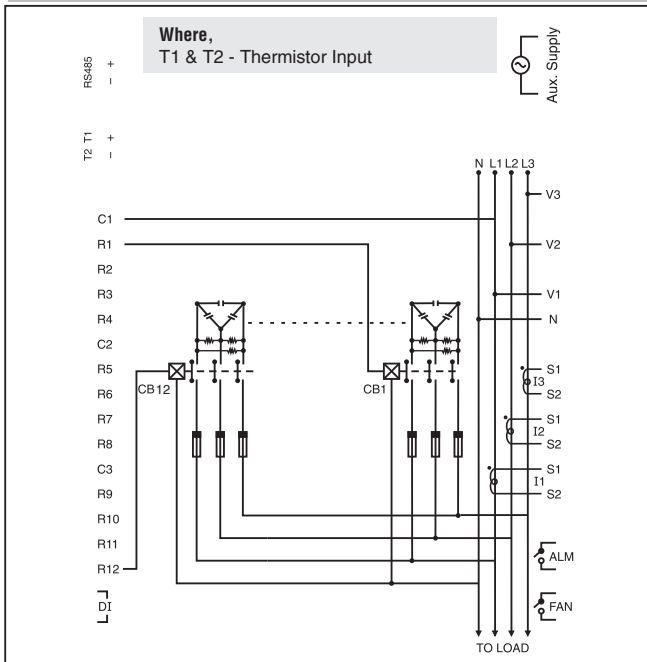

**3 PHASE - 3 WIRE**

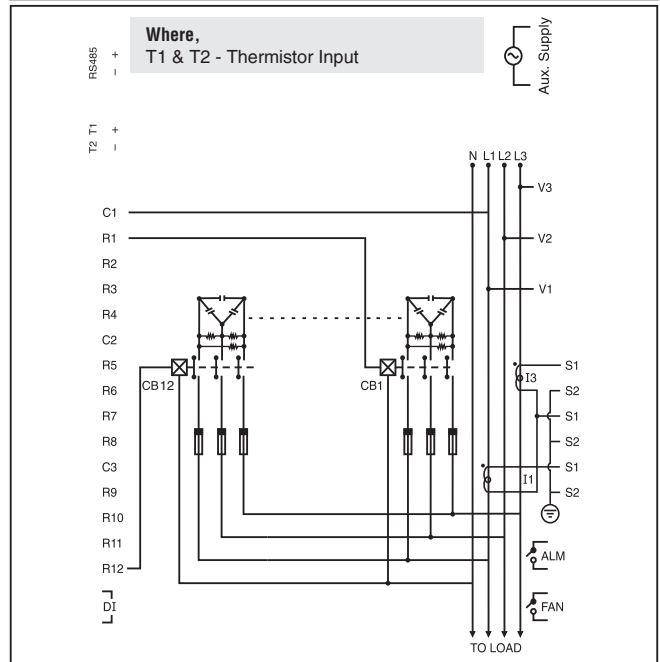

**1 PHASE - 2 WIRE**

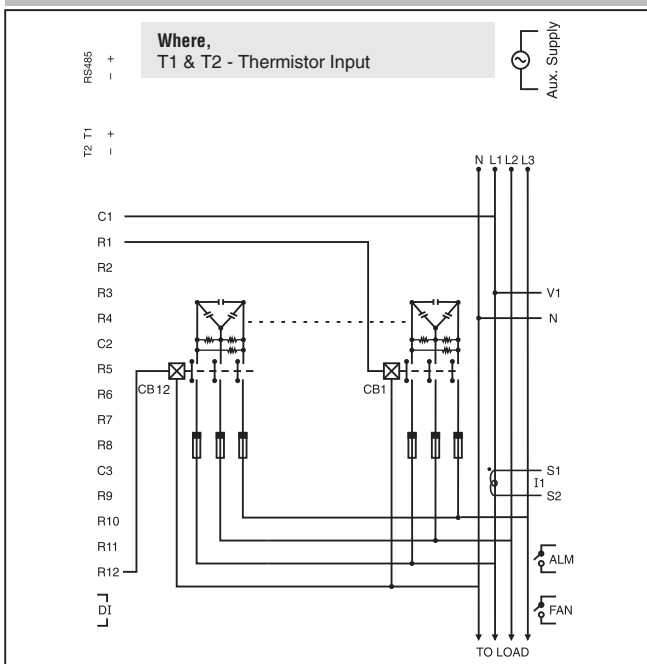

**2 PHASE - 2 WIRE**

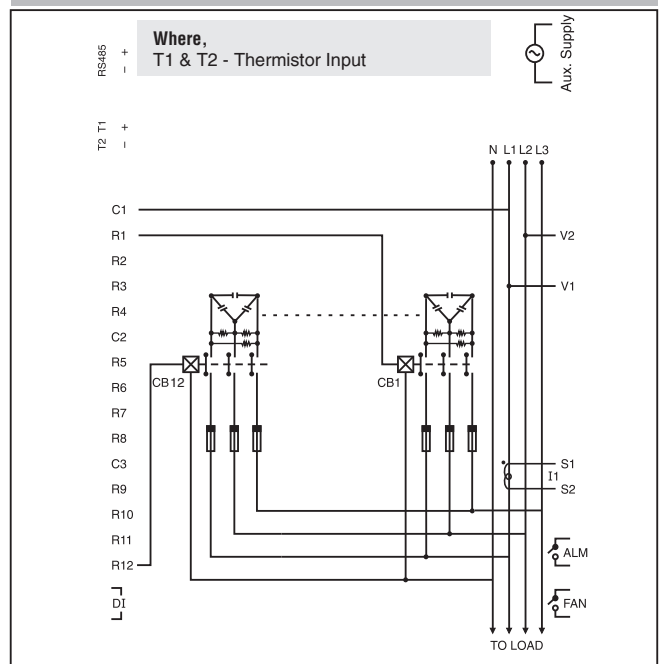

- NOTE :**
- For N/W selection 2P2W voltage ( $V_{LN}$ ) applied between V1 & V2 and connect CT for I1 [ Do not use V3, N, I2 & I3 terminal ]
  - For N/W selection 1P2W voltage ( $V_{LN}$ ) applied between V1 & N and connect CT for I1 [ Do not use V2, V3, I2 & I3 terminal ]

**PHASE-ANGLE SETTING**

Voltage	L1-N	L2-N	L3-N	L1-N	L2-N	L3-N	L1-N	L2-N	L3-N	L2-L3	L3-L1	L1-L2	L2-L3	L3-L1	L1-L2	L2-L3	L3-L1	L1-L2
CT	L1	L2	L3	L2	L3	L1	L3	L1	L2	L1	L2	L3	L2	L3	L1	L3	L1	L2
Phase-Angle	0°	0°	0°	240°	240°	240°	120°	120°	120°	90°	90°	90°	330°	330°	330°	210°	210°	210°

(Specifications are subject to change, since development is a continuous process.)

**Selec Controls Pvt. Ltd., India**

Factory Address :  
 EL-27/1, Electronic Zone, TTC Industrial Area,  
 MIDC, Mahape, Navi Mumbai - 400 710, INDIA.  
 Tel. No. : +91-22-41 418 419/430 | Fax No. : +91-22-28471733  
 Toll free : 1800 227 353 (BSNL/MTNL Subscribers only)  
 Website : www.selec.com | Email : sales@selec.com